

Economical, Automated Pipe Cutter Saves Layout and Fit-Up Time.

MM1

Programmable Pipe Cutter

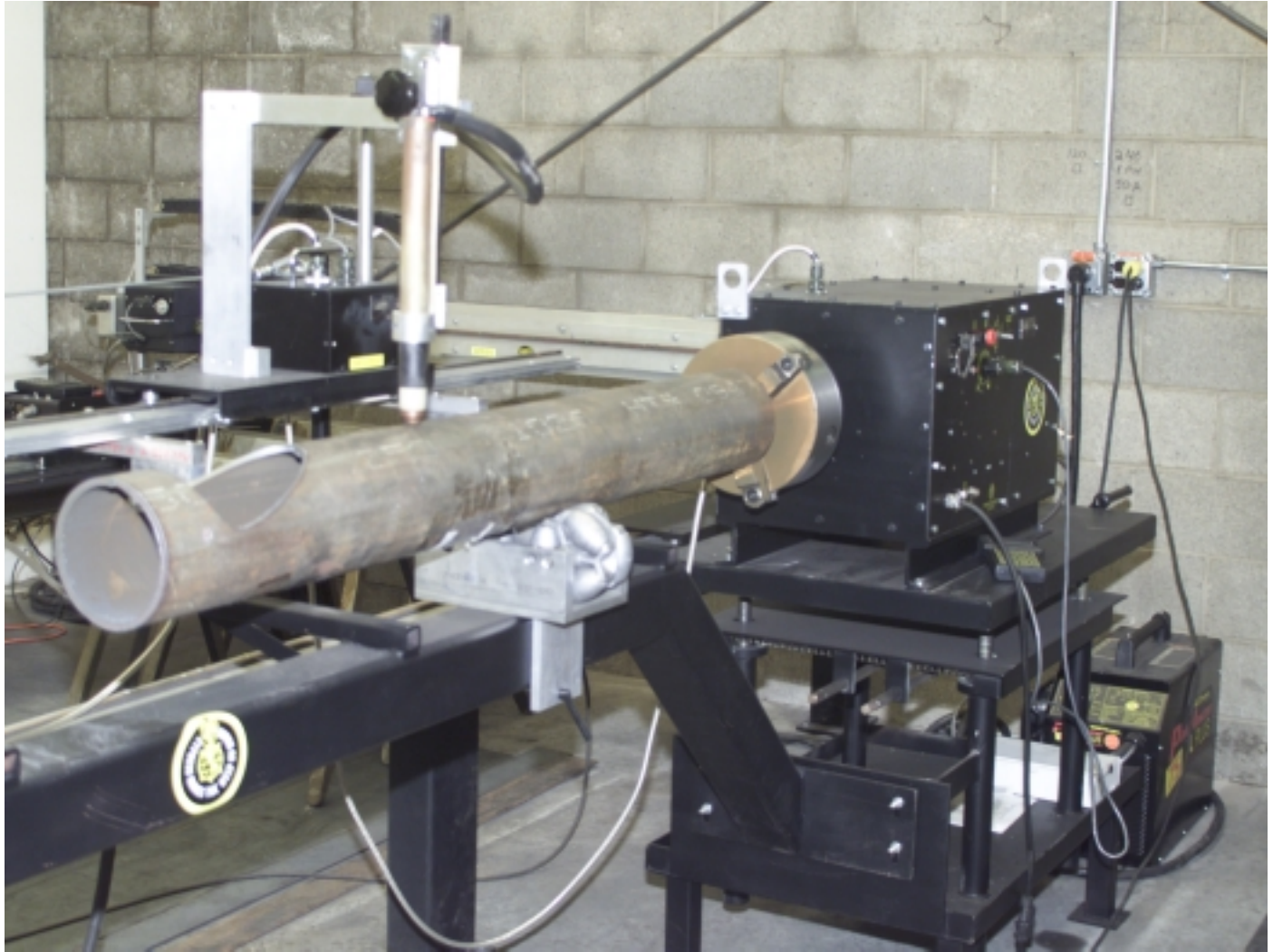

The MM1 is a computer-controlled machine that automates the cutting of profiles, holes and shapes on pipe with diameters from 4" to 16" (100-400 mm). It rotates the pipe on it's roller bed with a three jaw chuck while simultaneously moving a cutting torch back and forth along the pipe's axis. Pre-programmed shapes such as saddle, hillside, lateral and miter cuts can be made by simply selecting the type of cut from the menu, then entering the diameters of the pipe being processed and pressing the run button to cut your pipe. No need for templates. No time consuming layout or calculations to do. In addition irregular or uncommon shapes can be plotted, programmed and saved for future use.



CYPRESS WELDING EQUIPMENT INC.



A SUBSIDIARY OF WELD TOOLING CORPORATION

P.O. BOX 690168, HOUSTON, TEXAS 77269 Telephone: 1-281-469-0746 Fax: 1-281-469-9354
<http://www.cypressweld.com>

TECHNICAL DATA:

Cutting Diameter: 2"-16" O.D. (5-40 cm)
Load Capacity: 1600 lb. (725 kg)
Dimensions: 126"L x 36"W x 54"H
 (320 cm L x 91 cm W x 137 cm H)

Input Power: 115 VAC
Net Weight: 550 lbs (250 kg)
Shipping Weight: 800 lbs. (364 kg)

Types of Cuts:

A. Pipe Program

1. Saddle Cuts
2. Offset from Center-Line (Hillside)
3. Lateral Cuts
4. Miter Cuts
5. Hole Cuts

B. Shape Program

1. Custom Irregular Shapes

The machine's pipe bed is designed for handling lengths of pipe up to 6' (1.83 m) long. Additional pipe bed extensions of 8' (2.44 m) can be added to make up to a 30' (9.14 m) bed. The method of cutting can be oxy-fuel or plasma. If oxy-fuel is used, the machine will be equipped with solenoids and a three-hose cutting torch. When plasma is used, a rotary ground is installed on the machine. The machine can be delivered with plasma torch leads and power source or the customer may provide his own plasma equipment.

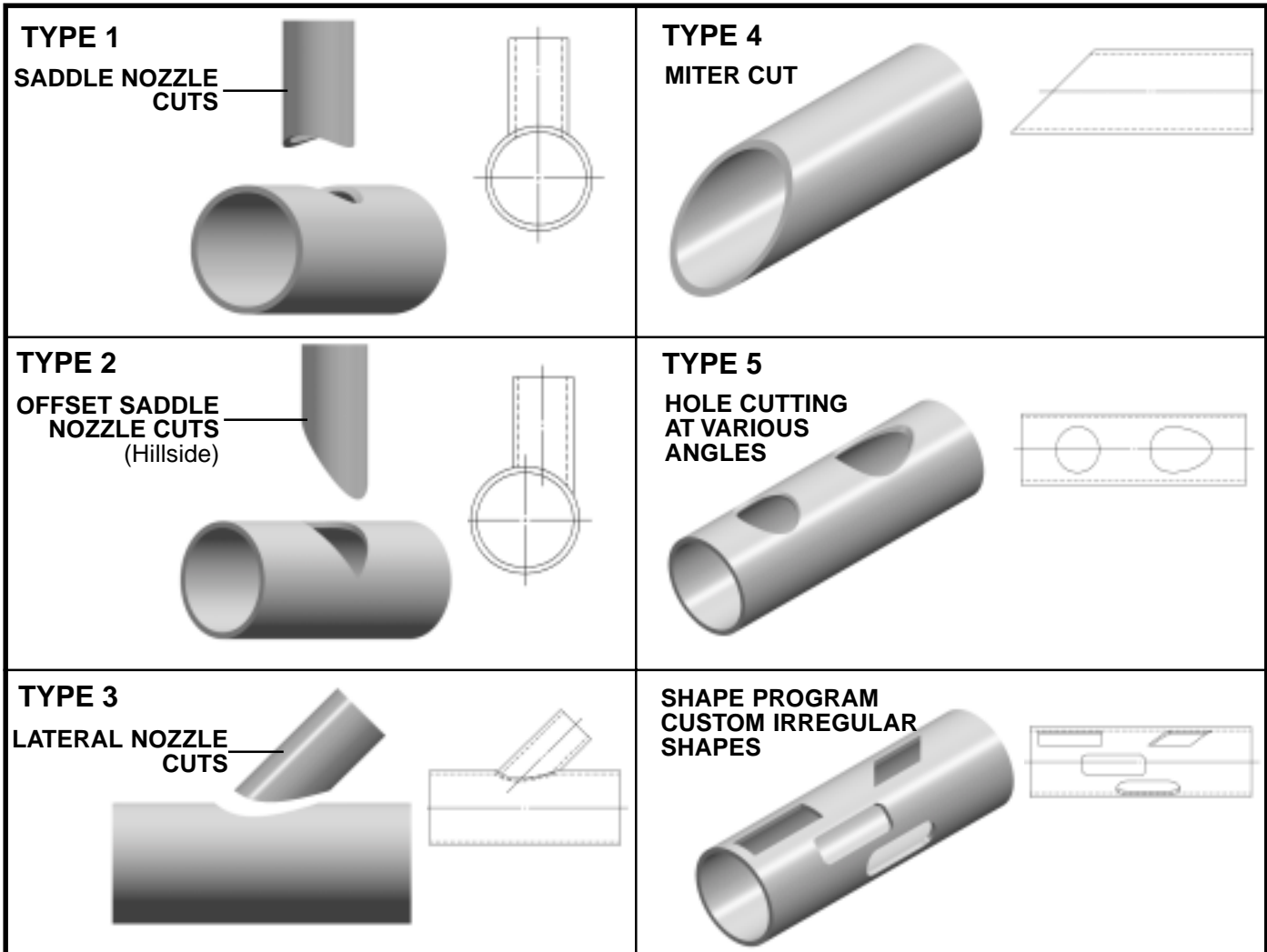

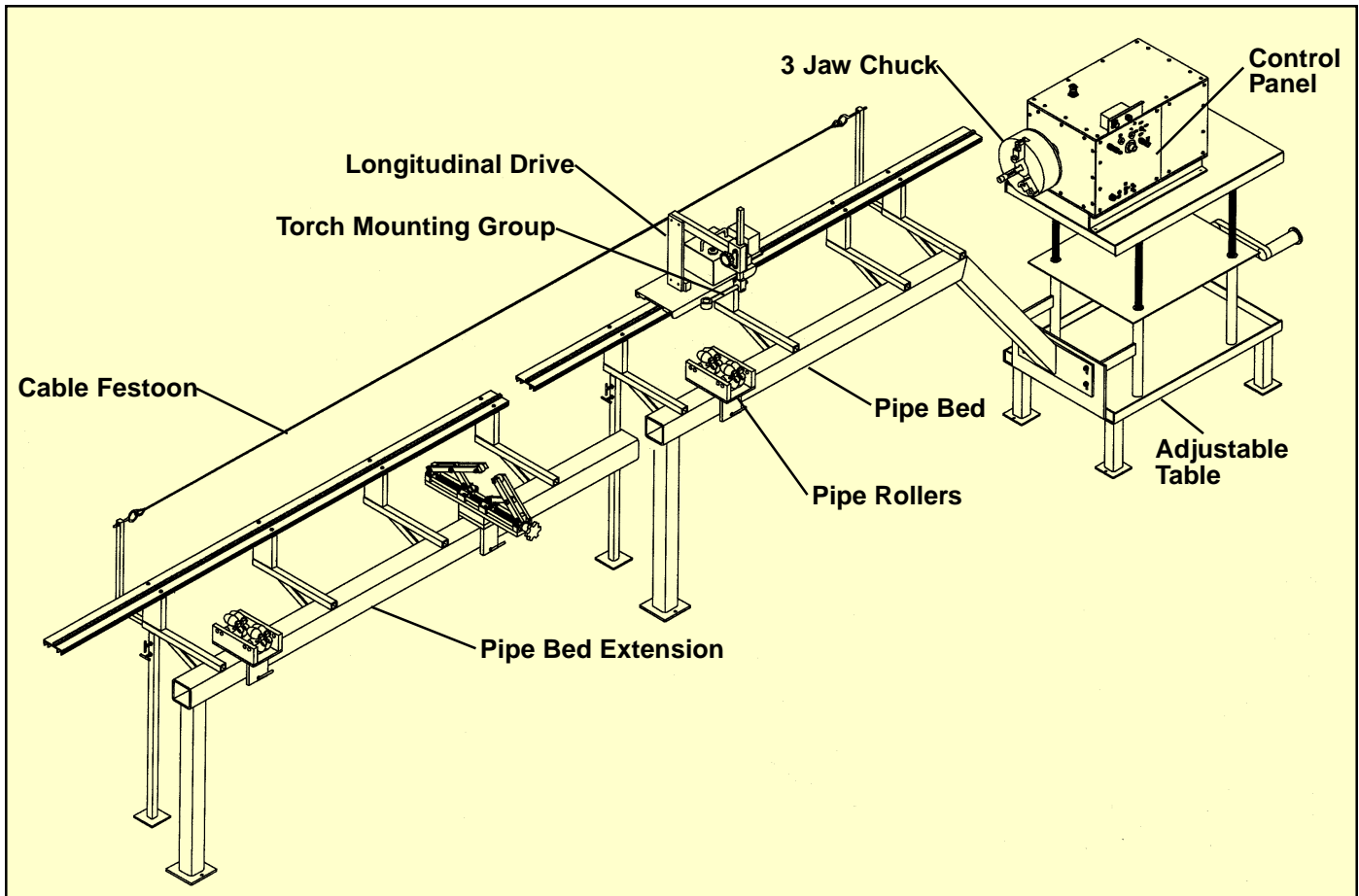

To cut a nozzle or hole, the sequence of actions would be to take the handheld terminal connected to the Control Panel and:

1. Press the reset button on the machine. The handheld terminal will display "READY".
2. Press "A" on the terminal. The terminal will ask you what type of cut you want. (See Types 1-5, Page 2).
3. Press the number desired and then press "ENTER".
4. The terminal will ask for the diameter of the small pipe. Press the appropriate dimensions and press "ENTER".
5. The terminal will ask for the diameter of the large pipe. Press the appropriate dimensions and press "ENTER".
6. Enter the offset dimension if cutting a hillside nozzle.
7. Enter the "ANGLE" in degrees if cutting a lateral.
8. Press "START" on the machine to begin to cut.

When using Plasma, press "B" and enter the time delay required (which is stored until changed again.)



Programming Custom Shapes.

The MM1 contains two software packages. For custom shapes select the "shape" software. Programming is simple but will require a few more steps due to all the variations possible.

First, the developed pattern should be laid out as if the pipe is unrolled flat. The cut is then split into a sequence of straight lines or circular arcs that make up the desired pattern.

Next, these should be listed in a table on paper, with the type, quadrant and required dimensions (referring to the chart in the Instruction Manual).

For example, to cut a slot like the one in the diagram, the shape would consist of the six segments shown. The first segment is a clockwise 90° arc, which is Type 1, in quadrant 3 and the required dimension is the radius.

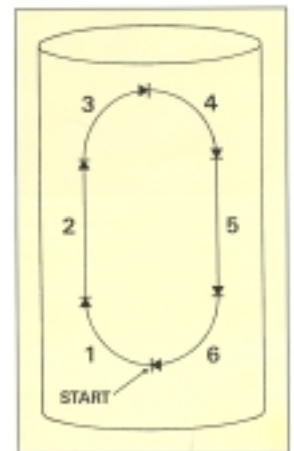

To program the shape, press "A", then enter the total segments at the prompt.

Next, the data for each segment – type, quadrant and dimensions – are entered in turn, at the prompt.

MM1

Programmable Pipe Cutter

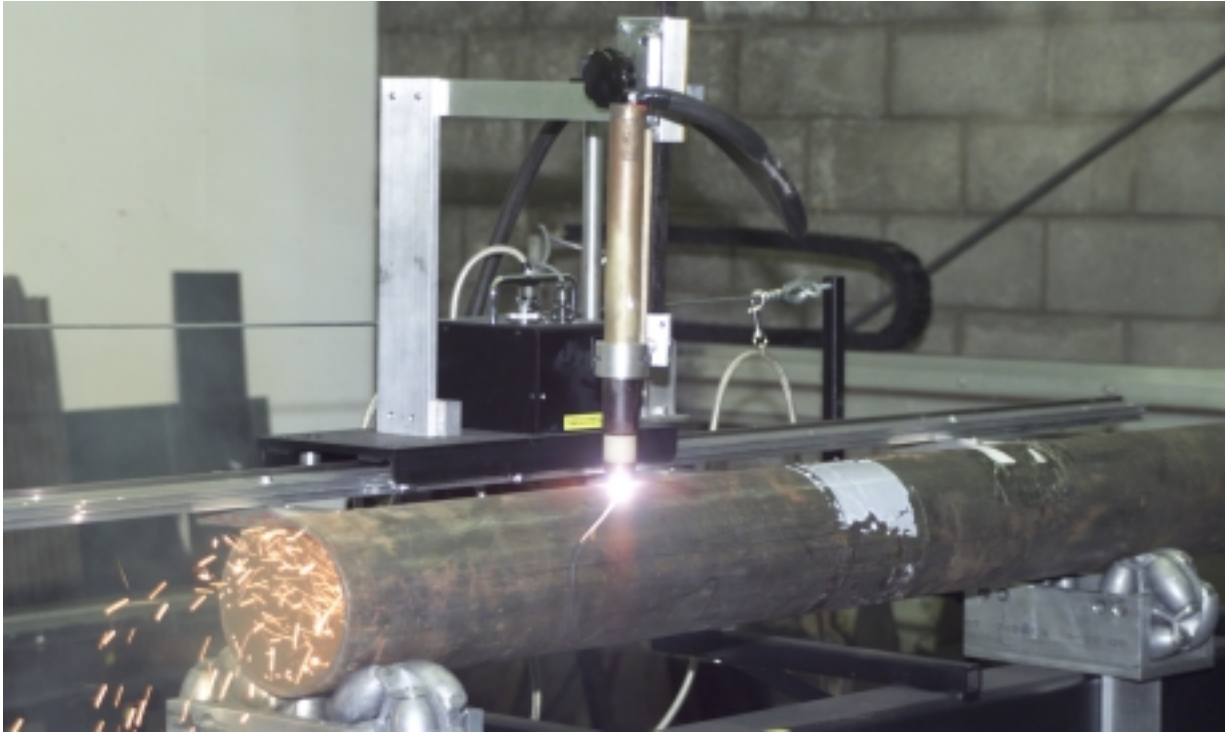

CYPRESS WELDING EQUIPMENT, INC.

A SUBSIDIARY OF WELD TOOLING CORPORATION

P.O. BOX 690168, HOUSTON, TEXAS 77269 Telephone: 1-281-469-0746 Fax: 1-281-469-9354
<http://www.cypressweld.com>

MM1-901